

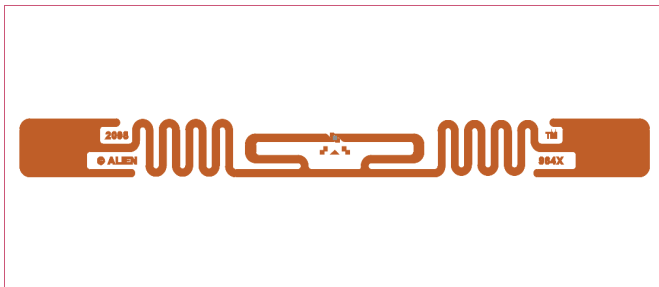

ALN-9640 Squiggle® Inlay

The Alien Technology® ALN-9640 Squiggle® is a high performance general purpose RFID inlay for use in a wide variety of applications



Powered by Alien®'s break-through Higgs™3 UHF RFID IC and innovative Squiggle antenna design, the ALN-9640 delivers industry leading EPC Gen 2 performance and reliability at competitive prices.

ALN-9640 inlays are World Tag compliant, enabling consistent operation across the diverse frequencies of the Americas, Europe, Middle East, Asia, and Africa.

With its Higgs-3 core, the Squiggle delivers unprecedented performance and a rich feature set including a 32-bit TID, a 64-bit Unique TID for authentication and serialization applications, an extensible EPC memory bank, 512-bits of user memory for distributed data applications, and password protected read and write support capabilities to prevent unauthorized viewing and modification of the tag's data.

Typical applications for the Squiggle include, but are not limited to, corrugate cases, pallet placards, apparel hang tags, baggage tags, shipping labels, asset management, and file folder labels.

FEATURES

- › Exceptional performance
- › EPC Gen 2 (v1.2.0) compliant
- › ISO/IEC 18000-6C compliant
- › Worldwide RFID UHF operation (840-960MHz)
- › Higgs™-3 IC with 800-bits of Nonvolatile Memory
 - 32-bit TID
 - 64-bit Unique TID
 - 96-bit EPC Memory, extensible to 480-bits
 - 512-bit User Memory
 - 32-bit Access password
 - 32-bit Kill password
- › Pre-programmed with a unique, unalterable 64-bit serial number (ideal for authentication)
- › User Memory can be Block Perma-Locked
- › User Memory can be Read Password protected in 64-bit blocks, prohibiting unintended Reads without an access password
- › Supports all Mandatory and Optional Gen 2 commands including item level commands
- › Custom commands for high speed programming
- › Available in high-yield, high-capacity dry/wet inlay rolls for high volume converting processes



ALN-9640 Squiggle® Inlay

ALN-9640 Inlay Orientation

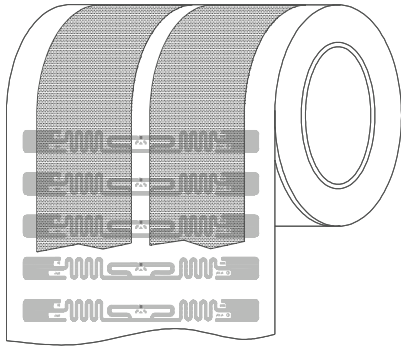

ALN-9640-FR
(Dry Unslit Roll)

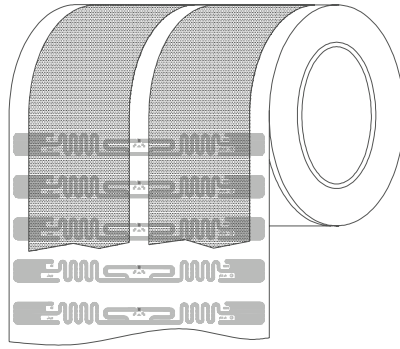

ALN-9640-FSR
(Dry Slit Roll)

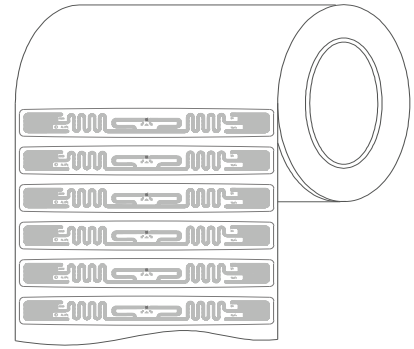

ALN-9640-FWRC / -FWRW
(Clear / White Wet Inlay)

Standard Alien Inlay rolls unwind with metal antenna side facing outward with respect to the core.

ALN-9640 Inlay Specifications

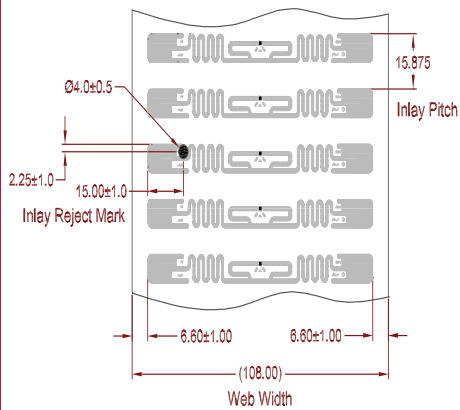

ALN-9640-FR
(Dry Unslit Roll)

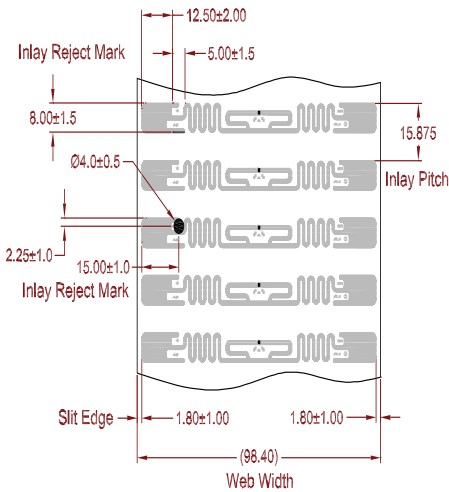

ALN-9640-FSR
(Dry Slit Roll)

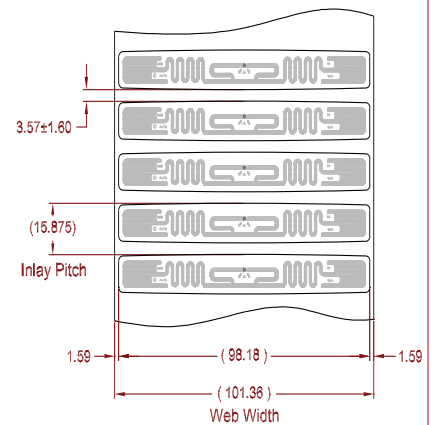

ALN-9640-FWRC / -FWRW
(Clear / White Wet Inlay)



ALN-9640 Squiggle® Inlay

ALN-9640 Inlay General Dimensions

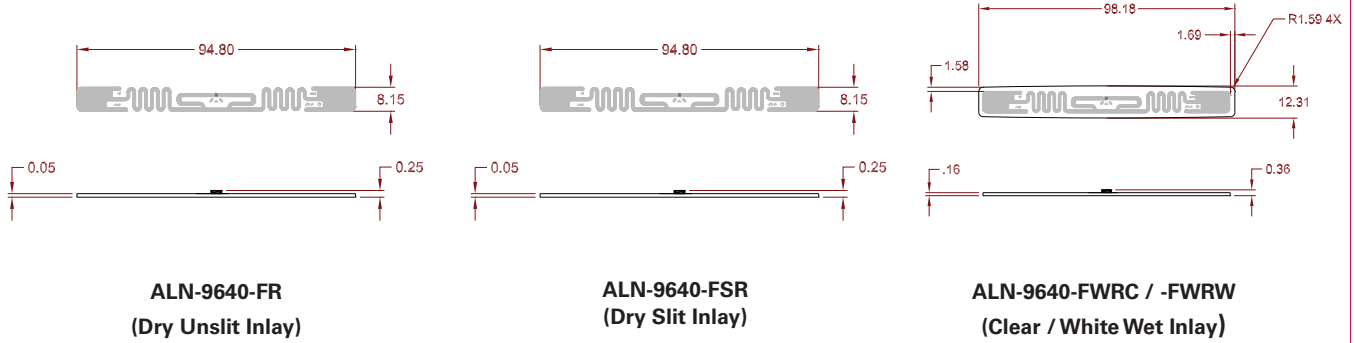

ALN-9640 Inlay Stackup

DRY INLAY THICKNESS, ±10%	
OVER ANTENNA	0.05 mm
OVER CHIP	0.25 mm

CLEAR WET INLAY THICKNESS, ±10%	
OVER ANTENNA	0.08 mm
OVER CHIP	0.28 mm

WHITE WET INLAY THICKNESS, ±10%	
OVER ANTENNA	0.16 mm
OVER CHIP	0.36 mm



ALN-9640-FR / -FSR
(Dry Unslit / Slit Inlay)



ALN-9640-FWRC
(Clear Wet Inlay)



ALN-9640-FWRW
(White Wet Inlay)

ALN-9640 Inlay Angular Sensitivity

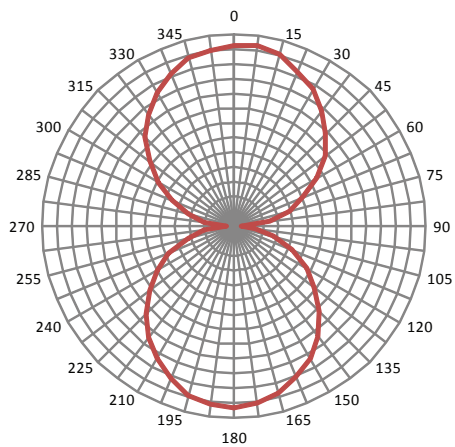

Angular Sensitivity
(Relative Read Range vs. Orientation)

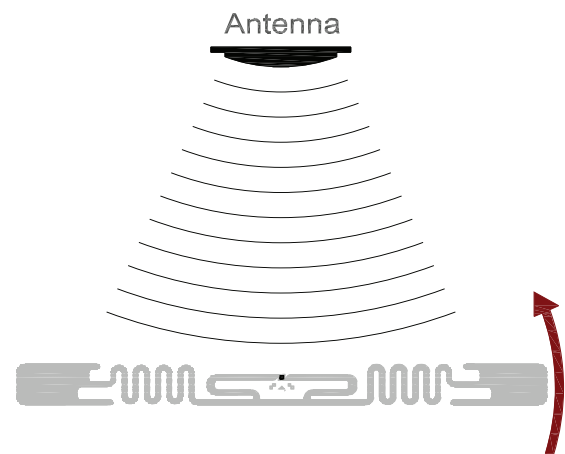

Angular Sensitivity
Inlay is rotated in the x, y, plane about the z axis
(tag shown at 0° with respect to face of antenna)



ALN-9640 Squiggle® Inlay

ALN-9640 Specifications

Dry Inlay

Antenna Width	3.732" [94.8mm]
Antenna Length	0.319" [8.1mm]
Web Width (-FR)	4.252" [108.0mm]
Web Width (-FSR)	3.874" [98.4mm]
Web Pitch	0.625" [15.875mm]
Core Width	3.874" [98.4mm]
Core ID	6" [152.4mm]
Core Material	Fiberboard
Interleaf Material	Paper
Interleaf Width	1.5" [38.1mm]
Inlays per Roll	20,000 Nominal
Maximum Roll OD	< 16" [406.4mm]
Roll Labeling Data	Roll #, Quantity

Wet Inlay

Inlay Width	3.866" [98.2mm]
Inlay Length	0.484" [12.3mm]
Web Width (-FWR)	3.992" [101.4mm]
Web Pitch	0.625" [15.875mm]
Core Width	4.752" [120.7mm]
Core ID	6" [152.4mm]
Core Material	Fiberboard
Inlays per Roll	20,000 Nominal
Maximum Roll OD	< 16" [406.4mm]
Roll Labeling Data	Roll #, Quantity
Overlay (-FWRW)	2.5 Mil White Polyolefin
Overlay Adhesive (-FWRW)	Acrylic
Inlay Adhesive	Acrylic
Adhesive Application Temperature	> +36.5°F [+2°C]
Adhesive Service Temperature	-4°F to +199.4°F [-20°C to +93°C]
Release Liner	40# SCK

Environmental

Shelf Life	2 Years at +77°F [+25°C] @ 40%RH
Recommended Storage	+77°F [+25°C] @ 40% RH
Storage Limits	-13°F to 122°F [-25°C to +50°C] 20% to 90% RH Non-condensing
Operating Limits	-40°F to +158°F [-40°C to +70°C] 20% to 90% RH Non-condensing
Bend Diameter	> 1.97" [50mm]
Pressure	< 5N/mm ²
Drop Resistance	Per ASTM D5276
Write Cycles	10,000
RoHs	2002/95/EC Compliant
ESD – HBM / CDM	> 5.0kV / > 1.5kV

RFID

ISO/IEC 18000-6C	
EPCglobal Class 1 Gen 2	
Integrated Circuit	Alien Higgs-3
EPCglobal Certificate	950110126000001084
Operating Frequency	840–960 MHz
EPC Size	96 - 480 Bits
User Memory	512 Bits
TID	32 Bits
Unique TID	64 Bits
Access Password	32 Bits
Kill Password	32 Bits

Copyright © 2010 Alien Technology Corporation

All rights reserved. Alien, Alien Technology, the Alien Technology logo, FSA™, Alien Higgs-3, Squiggle, and the Squiggle logo are trademarks or registered trademarks of Alien Technology Corporation in the U.S. and other countries.

HANDLING PRECAUTIONS Observe standard handling practices to minimize ESD.

DISCLAIMER Application recommendations are guidelines only - actual results may vary and should be confirmed. This is a general purpose product not designed or intended for any specific application.



Alien Technology
18220 Butterfield Blvd.
Morgan Hill, CA 95037
866-RFID NOW
www.alientechnology.com